



STANDARD SPECIFICATIONS

Performance

Platform Height	50-ft .5-in / 15.2-m
Horizontal Outreach	31-ft 6-in / 9.6-m
Centerline to Platform Edge	31-ft / 9.45-m
Swing	410 Degrees Non-Continuous
Platform Capacity	500-lb / 227-kg
Platform Capacity w/Rotator (Optional)	440-lb / 200-kg
Material Hook Capacity	500-lb / 227-kg
Platform Rotator	90 Degrees Manual
Jib Length	4-ft / 1.22-m
Jib Vertical Motion	130 Degrees (+75, -55)
Weight*	5,200-lb / 2,359-kg
Leveling Capability	11 Degrees
Max. Ground Bearing Pressure	31 psi / 2.18 kg/cm ²
Towing Speed Rating	65 mph / 105 km/h
Tongue Weight*	450-lb / 204-kg
Max Gradability	20%
Hydraulic Reservoir	6.0 gal / 22.71 L

*Certain options or country standards increase weight

Power Source

DC Power	24V DC
Gasoline Engine	Honda GX270 8.4hp

Tires

Standard	ST225/75 R15 Pneumatic
----------	------------------------

KEY SPECS

Platform Height
50-ft .5-in / 15.2-m

Towing Speed
65 mph / 105 km/h

Horizontal Outreach
31-ft 6-in / 9.6-m

Platform Capacity
500-lb / 227-kg

KEY FEATURES

- Optimize productivity with 8.4 hp gasoline engine.
- Increase productivity with standard features such as air and water lines to the platform.
- Set up with ease and get right to work with hydraulic, auto-leveling outriggers.
- Detachable platform controls provide efficient boom positioning with one-hand operation of all boom functions.

STANDARD FEATURES

- 110V-AC Receptacle in the Platform
- 2-in Hitch with Adjustable Height Coupler
- Amber Beacon
- ANSI A92.20 Compliant
- Auto-Leveling Hydraulic Outriggers
- Dual USB Port in Platform
- Hourmeter
- Hydraulic Surge Brakes
- LED Taillights & Mounting Bracket
- Lockable Hoods
- Motion Alarm
- Platform, Side Entry: 30 x 48-in (0.76 x 1.22-m)
- Proportional Controls
- Quick Start Guide Common Among all JLG® Towable Boom Models
- Smart Charger
- Standard Air and Water Lines to Platform
- Telescopic Upper Boom
- Tilt Alarm/Indicator Light

ACCESSORIES & OPTIONS

- 3000W Honda Generator (Aftermarket Only)
- Full-Size Spare Tire
- Lifting Lugs
- Material Hook — 500-lb / 227-kg Capacity
- Parking Brake Audible Indicator — COMING SOON!
- Platform Rotator

DIMENSIONS

All dimensions are approximate

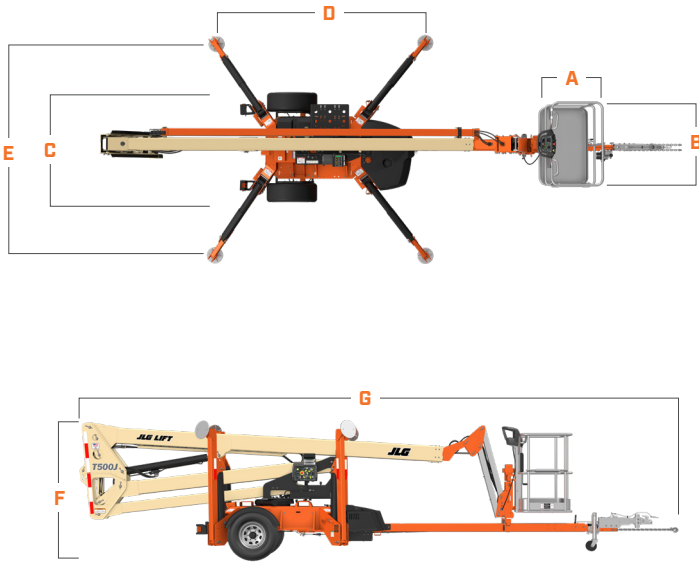

- A. Platform Width 30-in / 0.76-m
- B. Platform Length 48-in / 1.22-m
- C. Machine Width 5-ft 7.5-in / 1.7-m
- D. Outrigger Footprint Length 12-ft 4-in / 3.8-m
- E. Outrigger Footprint Width 12-ft 8-in / 3.9-m
- F. Machine Height 6-ft 6.75-in / 2-m
- G. Machine Length 27-ft 3.75-in / 8.32-m¹

¹ With surge brake, 2-in ball

REACH DIAGRAM

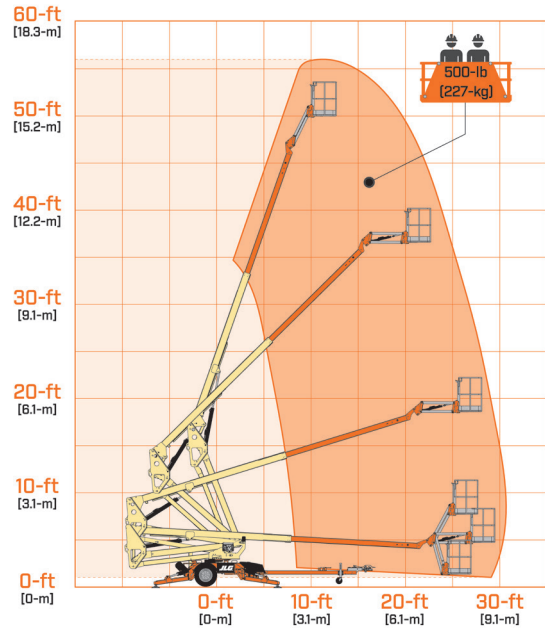

We provide coverage for one (1) full year, and cover all specified major structural components for five (5) years. Due to continuous product improvements, we reserve the right to make specification and/or equipment changes without prior notification. This machine meets or exceeds applicable ANSI and CSA requirements based on machine configuration as originally manufactured for intended applications. Please reference the serial number plate on the machine for additional information.



JLG INDUSTRIES, INC.
Toll-free US 877-JLG-LIFT
JLG.com

An Oshkosh Corporation Company