

CMP Attachments, LLC.

HYDRA BUCKET

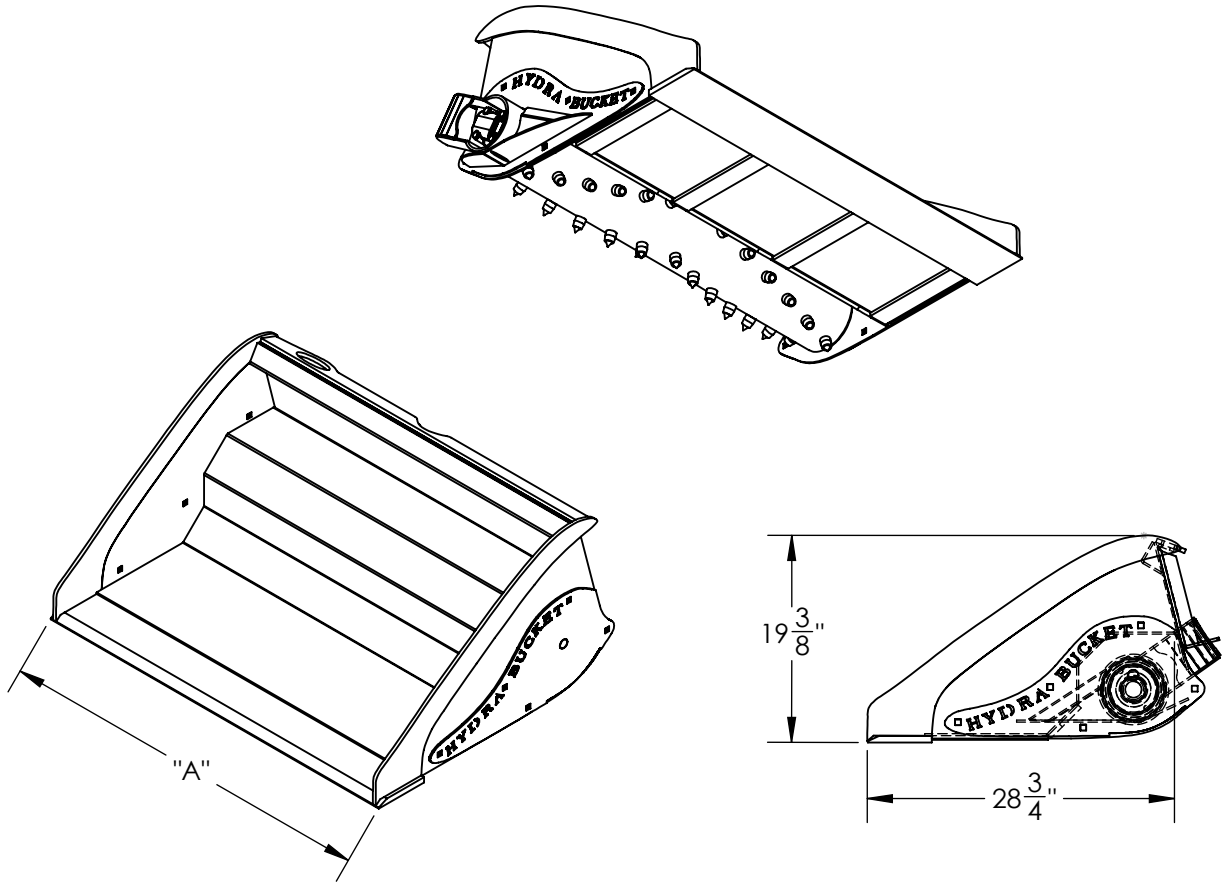

MODEL	WIDTH "A"	STRUCK VOLUME	HEAPED VOLUME	WEIGHT
MHB36	36"	5 1/2 FT ³	7 FT ³	410 LBS
MHB42	42"	6 1/4 FT ³	8 FT ³	430 LBS
MHB44	44"	6 3/4 FT ³	8 1/2 FT ³	440 LBS
MHB48	48"	7 1/4 FT ³	9 3/8 FT ³	460 LBS
MHB54	54"	8 FT ³	10 1/2 FT ³	480 LBS
MHB60	60"	9 FT ³	12 FT ³	500 LBS

Features

- Made with AR400, AR200, and grade 50 material
- 5" ball bearings that are triple sealed to protect from the elements.
- 2 cutting edges leading up to the drum to shred anything trying to get through.
- 6,700 in/lb Char-Lynn hydraulic motor housed inside the drum for ultimate protection.
 - Capable of handling 20GPM of hydraulic flow
 - Ultra hard carbide cutter teeth on drum.
- Get additional control from the direct-drive and powerful motor which only protrudes 2.5" beyond the side plate.
 - Crossover relief valves to help dampen shock to the hydraulic system.
 - Completely fabricated in our facility in Clear Lake Minnesota.