

CMP Attachments, LLC.

HYDRA BUCKET

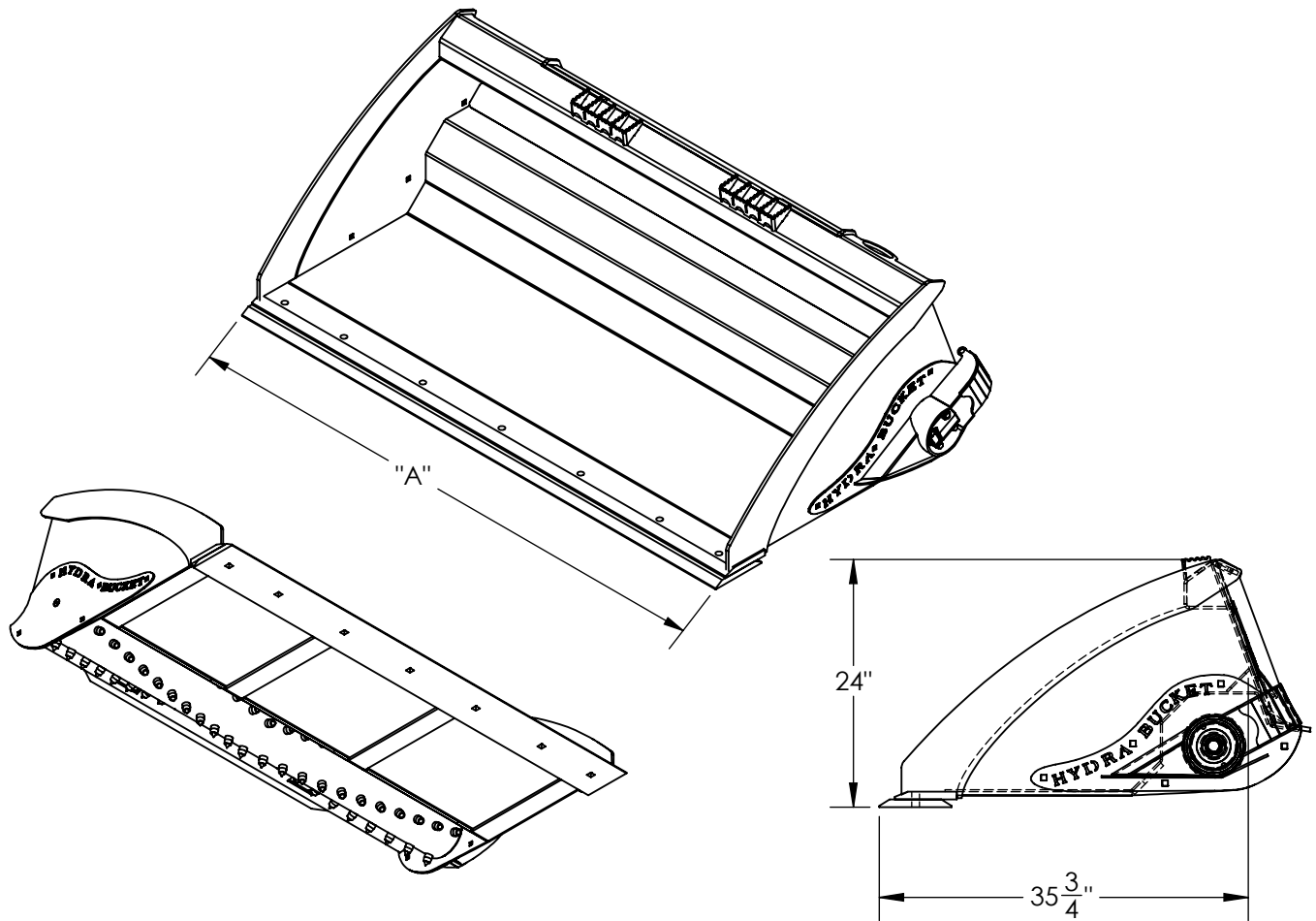

MODEL	WIDTH "A"	STRUCK VOLUME	HEAPED VOLUME	WEIGHT
HB60	60"	10 1/4 FT ³	15 3/4 FT ³	810 LBS
HB66	66"	11 1/4 FT ³	17 1/2 FT ³	870 LBS
HB72	72"	12 3/8 FT ³	19 FT ³	915 LBS
HB78	78"	13 3/8 FT ³	20 3/4 FT ³	960 LBS
HB84	84"	14 3/8 FT ³	22 1/2 FT ³	1015 LBS

Features

- Made with AR400, AR200, and grade 50 material
- 5" ball bearings that are triple sealed to protect from the elements.
- 2 cutting edges leading up to the drum to shred anything trying to get through.
- 6,700 in/lb Char-Lynn hydraulic motor housed inside the drum for ultimate protection.
 - Capable of handling 20GPM of hydraulic flow
 - Ultra hard carbide cutter teeth on drum.
- Get additional control from the direct-drive and powerful motor which only protrudes 2.5" beyond the side plate.
 - Crossover relief valves to help dampen shock to the hydraulic system.
 - Completely fabricated in our facility in Clear Lake Minnesota.